



VENTUS CONTINUOUS WAVE LASER SERIES

HIGH SPECIFICATION SCIENTIFIC LASERS

Novanta develops photonics solutions specializing in cutting-edge components and sub-systems for laser-based diagnostic, analytical, micromachining and fine material processing applications. Powerful lasers, coupled with advanced beam steering and intelligent sub-systems incorporating software and controls, deliver extreme precision and performance, tailored to our customers' demanding applications.

THE SCIENTIFIC CHOICE

With a long heritage in developing lasers for mission-critical industrial applications the ventus follows a design philosophy that delivers very high performance and reliability over the longest lifetimes. A small form factor and high wall plug electrical efficiency, delivering distinct benefits in thermal management. The ventus family offers a range of wavelengths and powers for a multitude of applications.

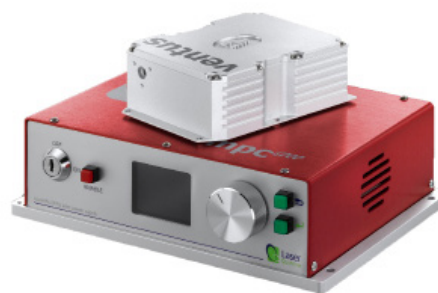

The ventus laser available in a range of wavelengths and powers

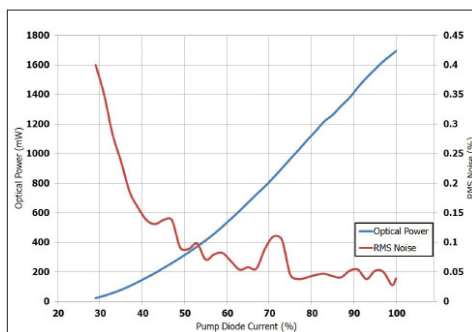

Fig. 1 Typical power curve of the ventus 532 nm laser, (blue) with the corresponding noise (red).

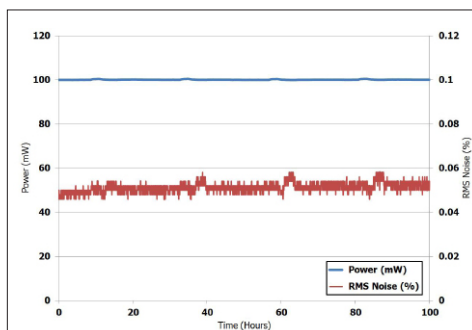

Fig. 2 Typical noise and power stability of the ventus 532 nm laser over 100 hours, depicting noise ~0.06 %.

THE SCIENTIFIC CHOICE

Repeatable, high-power performance delivering consistent results

- Exceptional power stability as power remains stable throughout gem's lifetime
- Tight focus and efficient fibre coupling for repeatable, consistent results
- High power on sample to optimise use in a diverse array of applications

Cost effective, customisable, flexible platform

- Efficient thermal management reducing cooling requirements and costs
- Available fibre coupling solutions at 70% efficiency above 500 mW, offering uniformed power at sample and increased productivity
- Customisable features delivering solution flexibility to OEM integrator

Ease of integration

- Compact size with high power; easy to retrofit into OEM platforms
- Simple plug and play solution increasing productivity and reducing downtime



Specification*	ventus 532	ventus solo	ventus 561	ventus 660	ventus 671
Wavelength	532 nm	532 nm	561 nm	660 nm	671 nm
Power	100 - 1500 mW	250 - 750 mW	100 - 750 mW	100 - 750 mW	100 - 500 mW
Beam Diameter ¹	1.5 ± 0.1 mm				
Spatial Mode	TEM ₀₀				
Ellipticity	<1:1.15	<1:1.2	<1:1.2	<1:1.2	<1:1.2
Bandwidth	30 GHz	10 GHz	40 GHz	30 GHz	30 GHz
Divergence	≤0.6 mrad	≤0.6 mrad	<1 mrad	<0.8 mrad	<0.8 mrad
M-Squared	<1.1	<1.1	<1.2	<1.2	<1.2
Power Stability (RMS) ²	<0.4%	<0.4%	<1.0%	<0.5%	<1.0%
Noise (RMS) ³	<0.15%	<1%	<1.5%	<0.5%	<0.6%
Noise Bandwidth	10 Hz - 100 MHz	10 Hz - 100 MHz	10 Hz - 50 kHz	10 Hz - 50 kHz	10 Hz - 50 kHz
Beam Pointing Stability	<10 μrad/°C				
Polarization Ratio	>100:1				
Polarization Direction ⁴	Horizontal				
Coherence Length	-1 cm	-3 cm	-7.5 mm	-1 cm	-1 cm
Beam Angle ⁵	<1 mrad				
Operating Temperature	15 - 40 °C				

* Laser Quantum operates a continuous improvement programme which can result in specifications being improved without notice.

¹ Beam diameter defined as the average of major and minor 1/e² beam size measured at 25 cm from exit port, at specified power.

² Test duration >100 hrs at constant temperature.

³ ventus 532 50 mW to 500 mW ≤0.4%.

⁴ Vertical polarization is available upon request.

⁵ Tolerance relative to head orientation.



DIMENSIONS (MM)

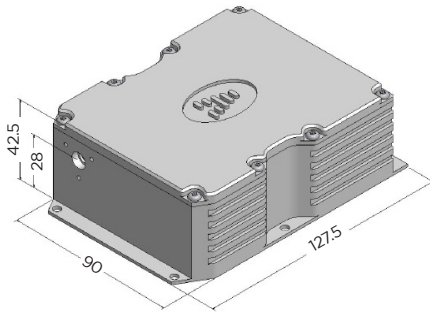

Drawings are for illustrative purposes only, please contact us for complete engineer's drawings

POWER SUPPLY UNIT

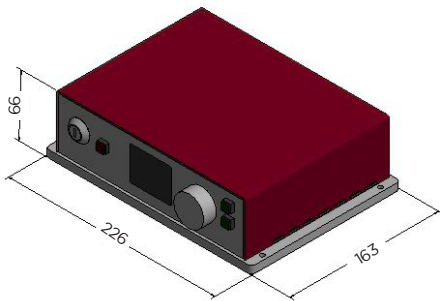

FLEXIBLE DESIGN

Customizable options available for your laser to optimize your application.

- **Fiber coupling:** Available with multi or single mode fiber delivery options which allows the beam to be delivered to the point of need.
- **Intelligent control unit:** Allows easy setting and monitoring of the laser parameters. Incorporating PowerLoQ™ technology, the gem lasers show extreme power stability over long periods of use.
- **1200 g drop-test:** (Fig. 2) All gem lasers undergo a drop test to check that all components are correctly fitted prior to its extended 300 hour test period. This rigorous testing regime ensures long operational lifetimes.
- **RemoteApp™:** Works with software that allows the laser to be controlled locally, over the internet and connected directly to our support team for monitoring laser performance, diagnosing opportunities and carrying out laser optimization.

ADDITIONAL INFORMATION

- Weight: 0.75 kg
- Umbilical length: 1.5 m
- Cooling options available
- System can be modulated
- Vertical polarization is available on request
- Fiber coupling available
- LabView drivers available
- 2 years unlimited hours warranty for scientific users

CONTACT US



海纳光学

电话: 0755-84870203
网址: www.highlightoptics.com